

R SERIES

2632R/3246R/4045R ELECTRIC SCISSOR LIFTS



Performance

Platform Height—Elevated (indoor / outdoor)		
2632R	25 ft 6 in. / 19 ft	7.8 m / 5.8 m
3246R	32 ft / 32 ft	9.8 m / 9.8 m
4045R	39 ft 3 in. / 29 ft	12 m / 8.8 m
Platform Capacity (indoor / outdoor)		
2632R	507 lb / 275 lb	230 kg / 125 kg
3246R	705 lb / 507 lb	320 kg / 230 kg
4045R	770 lb / 550 lb	350 kg / 250 kg
Capacity on Platform Extension		
2632R / 3246R	265 lb	120 kg
4045R	250 lb	113 kg
Lift/Lower Time		
2632R	56/42 seconds	
3246R	50/37 seconds	
4045R	73/48 seconds	
Maximum Drive Height		
2632R	Fully Elevated	
3246R	Fully Elevated	
4045R	Fully Elevated	
Weight*		
2632R	4,310 lb	1,955 kg
3246R	5,410 lb	2,454 kg
4045R	7,000 lb	3,175 kg
Ground Bearing Pressure		
2632R	92 psi	6.2 kg/cm ²
3246R	131 psi	9.2 kg/cm ²
4045R	135 psi	9.5 kg/cm ²
Drive Speed—Elevated		
Drive Speed—Lowered		
2632R	2.0 mph	3.2 km/h
3246R	2.2 mph	3.5 km/h
4045R	2.0 mph	3.2 km/h
Gradeability		
Turning Radius (Inside)		
Turning Radius (Outside)		
2632R	88 in.	2.2 m
3246R	93 in.	2.4 m
4045R	100 in.	2.5 m

* Certain options or country standards will increase weight.

Standard Specifications

Power Source

Batteries	
2632R/3246R	4 x 6V 220 amp-hr
4045R	4 x 12V 150 amp-hr
Charger	
27 amp	
Drive	
Hydraulic Front-Wheel	

Hydraulic Reservoir

• Capacity (at Full mark)		
2632R	4 gal.	15 L
3246R	4 gal.	15 L
4045R	6.6 gal.	25 L
• Pump		
Fixed Displacement Gear		

Tires

• Tire Size/Type (Non-Marking)		
2632R / 3246R / 4045R	16 x 5 in.	406 x 127 mm

Brakes

- Multi-Disc Friction



Standard Features

- Proportional Controls
- Battery Condition Indicator
- AC Receptacle in Platform
- All Motion Alarm
- 27 amp Multi-Function Universal Charger
- Horn
- Hourmeter
- Tilt Alarm and Light
- Lanyard Attach Points
- Movable, Removable Platform Control
- Nickel Plated Pins
- Lubrication Free Scissor Arm Bushings
- Scissor Maintenance Prop
- Active Pothole Protection System
- Lifting and Tie Down Points
- Fork Lift Pockets
- Foot-Actuated Deck Extension
- Steel Swing-Out Doors
- Variable Tilt Visual Zone Indicator
- Manual Descent Cable
- Diamond Tread Steel Deck
- Greaseless Kingpin Joints
- Analyzer Port for Diagnostics
- Dynamic Braking
- Removable Ladder
- ANSI 92.20 Compliant

Accessories & Options

- Coiled Platform Control Box Cable
- Drive Motor Covers
- Extension Deployment Handles
- Fire Extinguisher
- Flashing Amber Beacon
- MDI (Ground)
- Anti-Vandalism PKG
- Eagle Performance Charger
- 900W Inverter
- Ambient Noise Alarm
- Batteries, AGM (6V, 220AH) - 2632R/3246R
- Batteries (6V, 220AH) - 2632R/3246R
- Batteries (6V, 250) - 2632R
- Batteries (6V, 255AH) - 3246R
- Batteries (12V, 185AH) - 4045R
- Batteries, AGM (12V, 150AH) - 4045R
- Batteries, (12V, 150AH) - 4045R

R SERIES

4045R ELECTRIC SCISSOR LIFT



Dimensions

All dimensions are approximate.

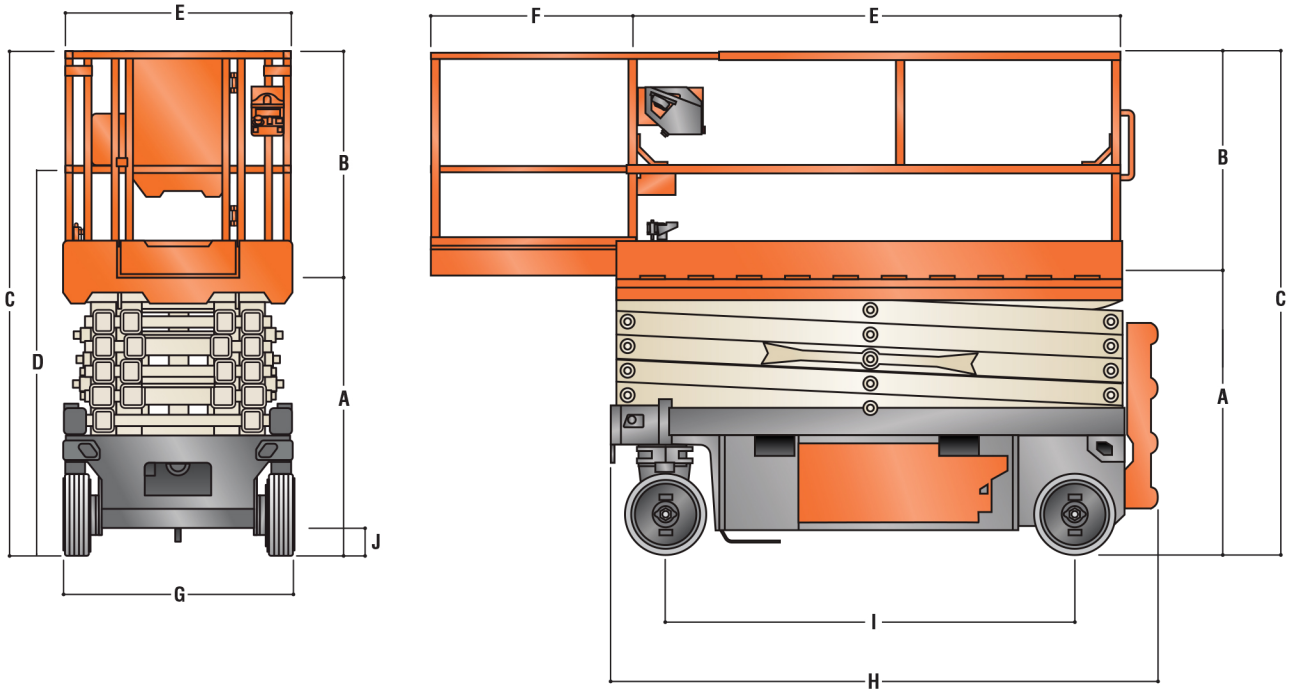

A. Platform Height-Lowered	55 in.	1.40 m	G Overall Width	45 in.	114.3 cm
B. Platform Railing Height	44 in.	1.132 m	H. Overall Length	106 in.	2.71 m
C. Overall Height	100 in.	2.53 m	Overall Length, Ladder Removed	101 in.	2.56 m
D. Stowed Height, Rails Folded	75 in.	1.9 m	I. Wheelbase	80 in.	2.03 m
E. Platform Size	41 in. x 96 in.	1.05 m x 2.43 m	J. Ground Clearance	5 in.	12.7 cm
F Platform Extension	36 in.	91 cm			

The JLG "1 & 5" Warranty

We provide coverage for one (1) full year, and cover all specified major structural components for five (5) years. Due to continuous product improvements, we reserve the right to make specification and/or equipment changes without prior notification. This machine meets or exceeds applicable ANSI and CSA requirements based on machine configuration as originally manufactured for intended applications. Please reference the serial number plate on the machine for additional information.



Part No.: 3131507
R091804
Printed in USA



JLG Industries, Inc.
1 JLG Drive
McConnellsburg, PA 17233-9533
Telephone 717-485-5161
Toll-free in US 877-JLG-LIFT
Fax 717-485-6417
www.jlg.com

An Oshkosh Corporation Company