

R SERIES

1932R ELECTRIC SCISSOR LIFT



Performance

Platform Height–Elevated	19 ft	5.8 m
Platform Capacity	550 lb	250 kg
Capacity on Platform Extension	250 lb	113 kg
Lift/Lower Time	25/26 seconds	
Maximum Drive Height	Fully Elevated	
Weight*	2,630 lb	1,193 kg
Ground Bearing Pressure	101 psi	7.66 kg/cm ²
Drive Speed–Elevated	0.5 mph	0.8 km/h
Drive Speed–Lowered	2 mph	3.2 km/h
Gradeability	25%	
Turning Radius (Inside)	Zero	
Turning Radius (Outside)	66 in.	1.68 m

* Certain options or country standards will increase weight.

Standard Specifications

Power Source

Batteries	4 x 6V 220 amp-hr
Charger	27 amp High Frequency Charger
Drive	Hydraulic Front-wheel

Hydraulic Reservoir

• Capacity	4.5 gal.	17 L
• Pump	Fixed Displacement Gear	

Tires

• Tire Size/Type (Non-marking)	12 x 4 in.	323 x 100 mm
--------------------------------	------------	--------------

Brakes

- Multi-disc Friction

Standard Features

- Proportional Controls
- Battery Condition Indicator
- 110V-AC Receptacle in Platform
- All Motion Alarm
- 27 amp Multi-function Universal Charger
- Horn
- Hourmeter
- Tilt Alarm and Light
- Lanyard Attach Points
- Movable, Removable Platform Control
- Nickel Plated Pins
- Lubrication Free Scissor Arm Bushings
- Scissor Maintenance Prop
- Active Pothole Protection System
- Lifting and Tie Down Points
- Fork Lift Pockets
- 36 in. (91 cm) Foot-actuated Deck Extension
- Steel Swing-out Doors
- Variable Tilt Window
- Manual Descent Cable
- Diamond Tread Steel Deck
- Greaseless Kingpin Joints
- Analyzer Port for Diagnostics
- Dynamic Braking
- Removable Ladder



Accessories & Options

- Coiled Platform Control Box Cable
- Drive Motor Covers
- Extension Deployment Handles
- Fire Extinguisher
- Flashing Amber Beacon
- MDI (Ground)
- Anti-vandalism PKG
- Eagle Performance Charger
- 900W Inverter
- Ambient Noise Alarm
- Batteries (220AH - AGM)

R SERIES

1932R ELECTRIC SCISSOR LIFT



Dimensions

All dimensions are approximate.

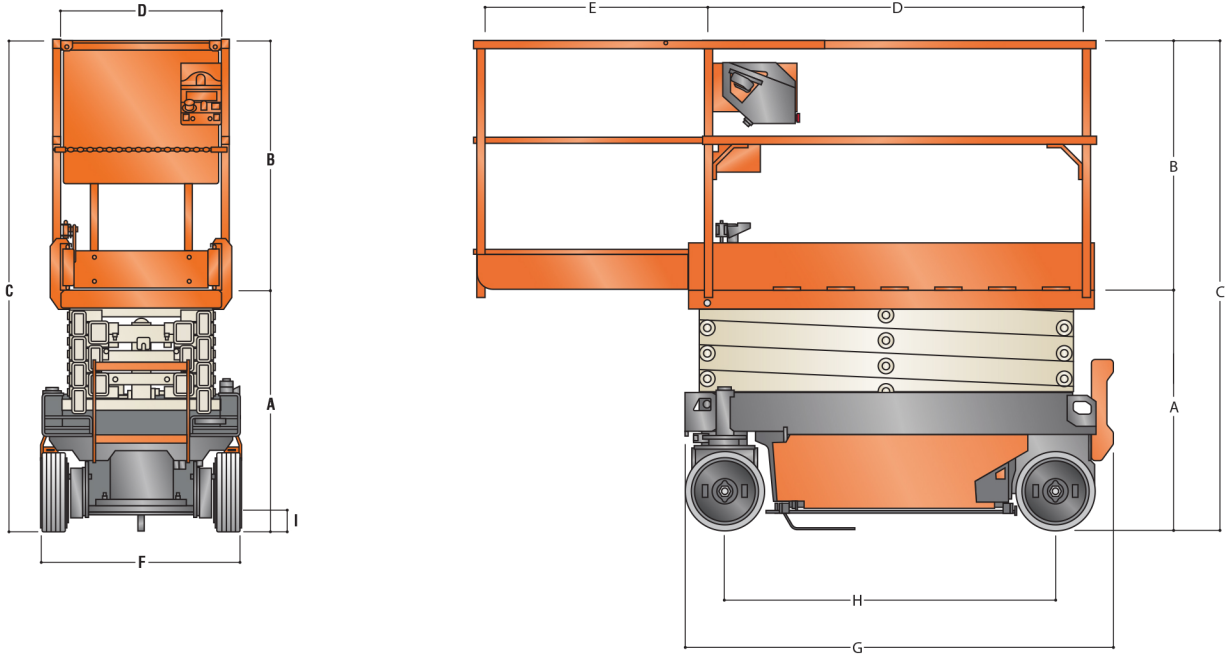

A. Platform Height-Lowered	38.6 in.	0.98 m	F. Overall Width	32 in.	81 cm
B. Platform Railing Height	39.9 in.	1.02 m	G. Overall Length	68.7 in.	1.74 m
C. Overall Height	78.5 in.	1.99 m	H. Wheelbase	53 in.	1.34 m
D. Platform Size	254 in. x 62.7 in.	0.64 m x 1.59 m	I. Ground Clearance	2.8 in.	7 cm
E. Platform Extension	36 in.	91 cm			

The JLG "1 & 5" Warranty

We provide coverage for one (1) full year, and cover all specified major structural components for five (5) years. Due to continuous product improvements, we reserve the right to make specification and/or equipment changes without prior notification. This machine meets or exceeds applicable ANSI and CSA requirements based on machine configuration as originally manufactured for intended applications. Please reference the serial number plate on the machine for additional information.



Part No.: 3131505
R121704
Printed in USA



JLG Industries, Inc.
1 JLG Drive
McConnellsburg, PA 17233-9533
Telephone 717-485-5161
Toll-free in US 877-JLG-LIFT
Fax 717-485-6417
www.jlg.com

An Oshkosh Corporation Company