

Self-Propelled Scissor Lifts

GS™ -2046, GS-2646 & GS-3246

Specifications

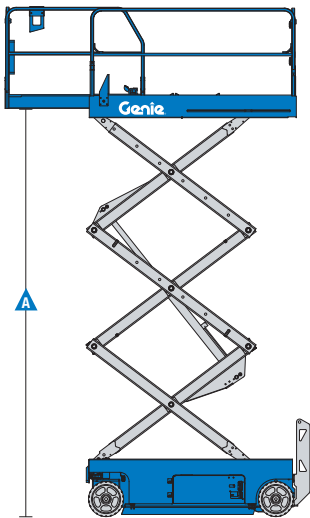
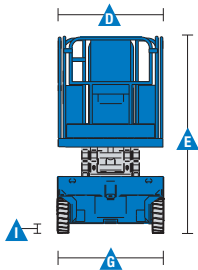
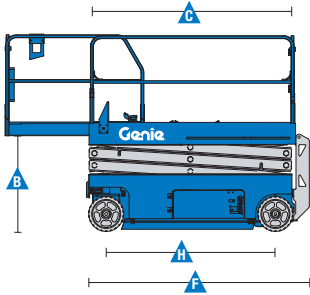

Models	GS-2046		GS-2646		GS-3246	
Measurements	US	Metric	US	Metric	US	Metric
Working height maximum ¹	26 ft	8.10 m	32 ft	9.92 m	38 ft	11.75 m
A Platform height maximum	20 ft	6.10 m	26 ft	7.92 m	32 ft	9.75 m
B Platform height stowed	3 ft 5 in	1.04 m	3 ft 10 in	1.16 m	4 ft 3 in	1.29 m
C Platform length - outside	7 ft 5 in	2.26 m	7 ft 5 in	2.26 m	7 ft 5 in	2.26 m
extended	10 ft 5 in	3.18 m	10 ft 5 in	3.18 m	10 ft 5 in	3.18 m
Slide-out platform extension deck	3 ft	0.91 m	3 ft	0.91 m	3 ft	0.91 m
D Platform width - outside	3 ft 9.5 in	1.16 m	3 ft 9.5 in	1.16 m	3 ft 9.5 in	1.16 m
Guardrail height	3 ft 7 in	1.09 m	3 ft 7 in	1.09 m	3 ft 7 in	1.09 m
Toeboard height	6 in	0.15 m	6 in	0.15 m	6 in	0.15 m
E Height - stowed: folding rails	7 ft	2.13 m	7 ft 5 in	2.26 m	7 ft 10 in	2.39 m
rails folded	5 ft 1 in	1.55 m	5 ft 6 in	1.68 m	5 ft 11 in	1.80 m
F Length - stowed	8 ft	2.44 m	8 ft	2.44 m	8 ft	2.44 m
extended	10 ft 11 in	3.33 m	10 ft 11 in	3.33 m	10 ft 11 in	3.33 m
G Width	3 ft 10 in	1.16 m	3 ft 10 in	1.16 m	3 ft 10 in	1.16 m
H Wheelbase	6 ft 1 in	1.85 m	6 ft 1 in	1.85 m	6 ft 1 in	1.85 m
A Ground clearance - center	3.75 in	10 cm	3.75 in	10 cm	3.75 in	10 cm
- with pothole guards deployed	0.75 in	2 cm	0.75 in	2 cm	0.75 in	2 cm

Productivity

Maximum platform occupancy	4		3		2	
Lift capacity	1,200 lbs	544 kg	1,000 lbs	454 kg	700 lbs	318 kg
Lift capacity - extension deck	250 lbs	113 kg	250 lbs	113 kg	250 lbs	113 kg
Drive height	full height		full height		full height	
Drive speed - stowed	2.0 mph	3.2 km/h	2.0 mph	3.2 km/h	2.0 mph	3.0 km/h
Drive speed - raised	0.5 mph	0.8 km/h	0.5 mph	0.8 km/h	0.5 mph	0.8 km/h
Gradeability - stowed ²	30%		30%		25%	
Turning radius - inside	zero		zero		zero	
Turning radius - outside	7 ft 6 in	2.29 m	7 ft 6 in	2.29 m	7 ft 6 in	2.29 m
Raise / lower speed	28 / 28 sec		28 / 28 sec		57 / 28 sec	
Controls	proportional		proportional		proportional	
Drive	dual front wheel		dual front wheel		dual front wheel	
Multiple disc brakes	dual rear wheel		dual rear wheel		dual rear wheel	
Tires - solid non-marking	15 x 5 in	38 x 13 cm	15 x 5 in	38 x 13 cm	15 x 5 in	38 x 13 cm

Power

Power source	24 V DC (four 6 V 225 Ah batteries)	24 V (four 6 V 225 Ah batteries)	24 V (four 6 V 225 Ah batteries)	
Hydraulic system capacity	4.5 gal	17 L	4.5 gal	17 L

Weight³ / Floor Loading⁴

Weight - ANSI/CSA	3,977 lbs	1,804 kg	4,312 lbs	1,956 kg	5,211 lbs	2,364 kg
Tire load, maximum:	2,035 lb	923 kg	2,150 lb	975 kg	2,251 lb	1,021 kg
Tire contact pressure:	136 psi	936 kPa	143 psi	988 kPa	150 psi	1,035 kPa
Occupied floor pressure:	181 psf	8.66 kPa	185 psf	8.87 kPa	208 psf	9.95 kPa

Standards Compliance ANSI A92.6, CSA B354.2, CE Compliance, AS 1418.10

¹ The metric equivalent of working height adds 2 m to platform height. U.S. adds 6 ft to platform height.

² Gradeability applies to driving on slopes, see operator's manual for details regarding slope ratings.

³ Weight will vary depending on options and/or country standards.

⁴ Note: Floor loading information is approximate and does not incorporate different option configurations. It should be used only with adequate safety factors.

Features

Standard Features

Measurements

GS-2046

- 26 ft (8.10 m) working height
- Up to 1,200 lbs (545 kg) lift capacity

GS-2646

- 32 ft (9.92 m) working height
- Up to 1,000 lbs (454 kg) lift capacity

GS-3246

- 38 ft (11.75 m) working height
- Up to 700 lbs (318 kg) lift capacity

Productivity

- 89 x 45.3 in (2.26 x 1.15 m) steel platform
- 36 in (.91 m) extension deck
- Folding rails with full height swing gate
- Drive at full height
- Dual front wheel drive
- Universal 27A smart charger
- Rear recessed charger receptacle
- SmartLink™ - proportional lift and drive
- Platform control with battery charge indicator and diagnostic display
- On-board diagnostic system
- AC power to platform
- Lanyard attachment points
- Manual platform lowering valve
- Emergency stop at both platform and ground controls
- Rear wheel multiple disc brakes
- Front wheel hydraulic dynamic braking
- Manual hydraulic brake release
- Swing-out component trays
- Solid non-marking tires
- Pothole guards
- Tilt level sensor with audible alarm
- Dual flashing LED beacons
- Descent alarm
- Electronic horn
- Hour meter
- Motion alarm

Power

- 24 V DC (four 6 V 225 Ah batteries)

Options & Accessories

Productivity Options

- Air line to platform
- Automotive horn*
- Biodegradable hydraulic fluid
- Platform control guard

Power Options

- Power inverter (120 V/60 Hz)¹
- EE rating
- AGM maintenance-free batteries
- Drive cutout while charging



¹ Not available with EE rating

Genie United States

6464 185th Ave. NE
Redmond, WA 98052
Telephone +1 (425) 881-1800
Toll Free in USA/Canada +1 (800)-536-1800
Fax +1 (425) 883-3475

Distributed By:



Effective Date: January, 2019. Product specifications and prices are subject to change without notice or obligation. The photographs and/or drawings in this document are for illustrative purposes only. Refer to the appropriate Operator's Manual for instructions on the proper use of this equipment. Failure to follow the appropriate Operator's Manual when using our equipment or to otherwise act irresponsibly may result in serious injury or death. The only warranty applicable to our equipment is the standard written warranty applicable to the particular product and sale and we make no other warranty, express or implied. Products and services listed may be trademarks, service marks or trade names of Terex Corporation and/or their subsidiaries in the USA and many other countries. Terex, Genie and AWP are registered trademarks of Terex Corporation or its subsidiaries. © 2019 Terex Corporation.