

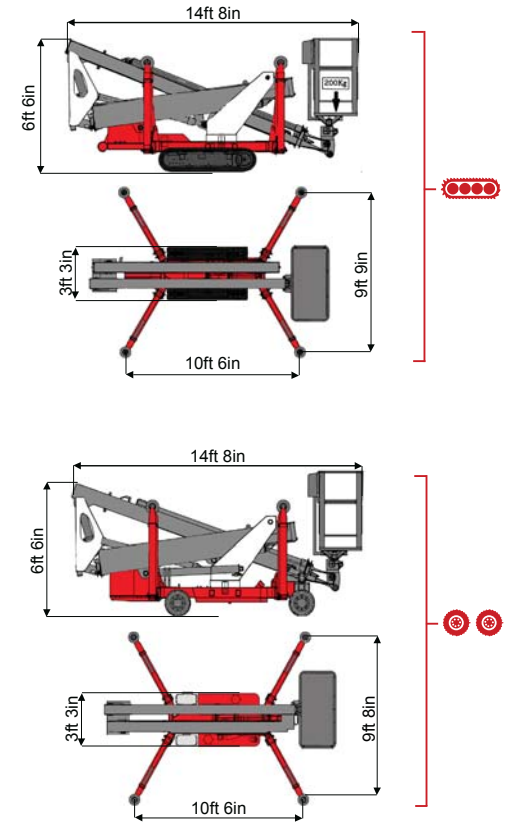

55ft 9in ↑
25ft 7in →
440 lb 👤 👤

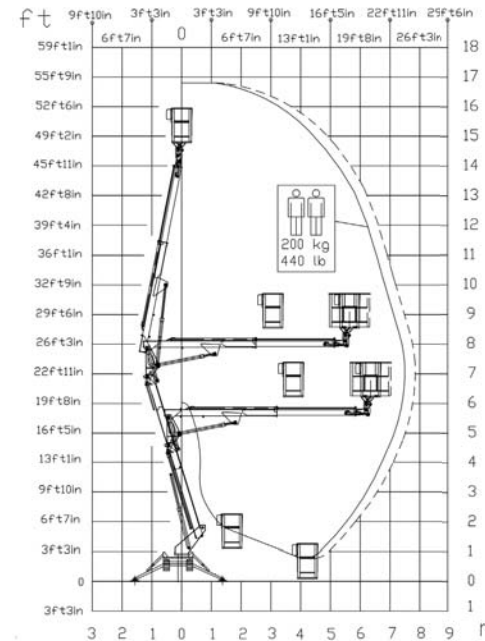

BI-ENERGY Diesel+AC																			
TZX 550/C			55ft 9in	25ft 7in	440 lb	360°	4ft 7in/2ft 4in	90°+90°	9ft 8in	15%	20%	1,24 mph	4409 lb	2866 lb	5428,8 psf	751,7 psf	3ft 3in	14ft 8in	6ft 6in
TZX 550/R			55ft 9in	25ft 7in	440 lb	360°	4ft 7in/2ft 4in	90°+90°	9ft 8in	15%	20%	1,24 mph	4409 lb	2866 lb	5428,8 psf	9938,9 psf	3ft 3in	14ft 8in	6ft 6in

	Battery type	Battery charge	Add. Weight	Autonomy	Charging time	Electropump	
ECO	DC+AC	24V 240 A/h 5h	230V-24V 40A	510 lb	3-4 h endless	6h	24V 5.5 kW



COMPANY WITH
QUALITY SYSTEM
CERTIFIED BY DNV GL
= ISO 9001 =