

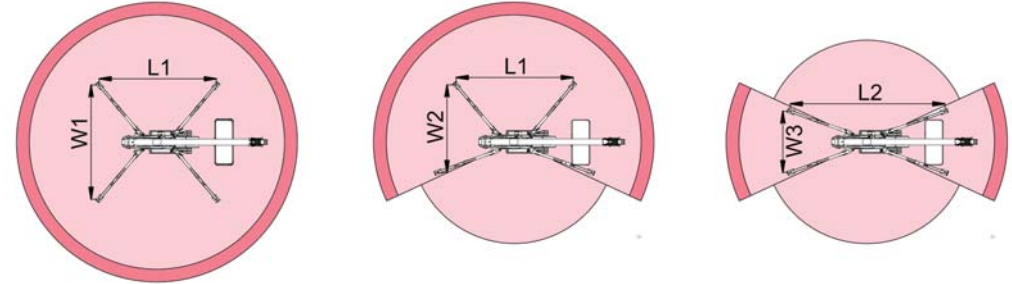

98ft 5in ↑
42ft 8in →
510 lb 🧑🧑

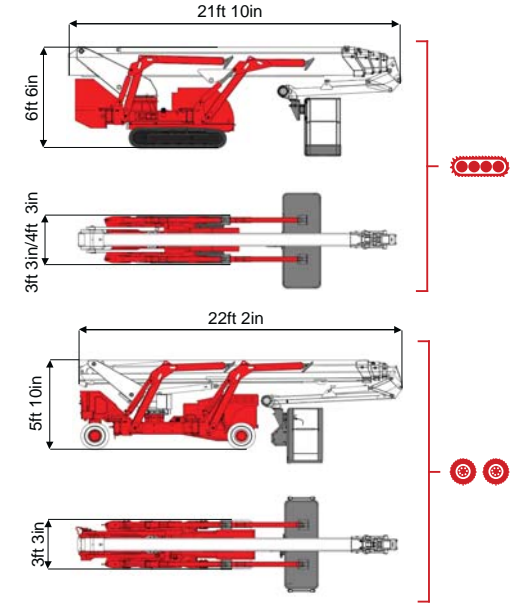

39ft 4in	42ft 8in	26ft 3in	L1	L2	W1	W2	W3
510 lb	264 lb	264/510 lb	16ft 8in	21ft 3in	15ft	12ft	9ft

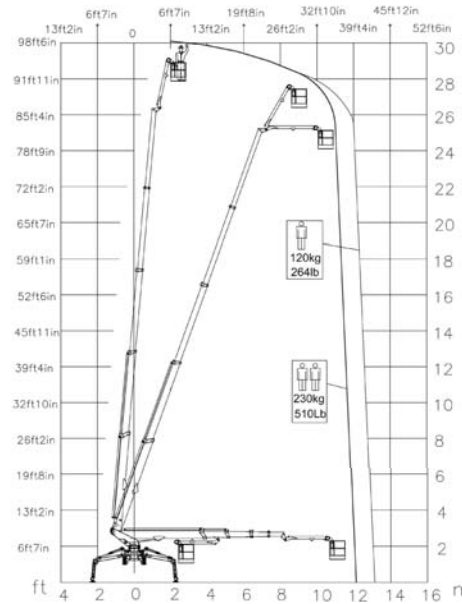

TSJ 98/C	🔋🔋🔋	98ft 5in	42ft 8in	510 lb	175°	540°	5ft 11in/2ft 4in	90°+80°	16ft 5in-9ft 5in	26%	40%	1,06 mph	10252 lb	6394 lb	48,02 psf	77,67 psf	3ft 3in/4ft 3in	21ft 10in	6ft 6in
TSJ 98/R	🔋🔋	98ft 5in	42ft 8in	510 lb	175°	540°	5ft 11in/2ft 4in	90°+80°	16ft 5in-9ft 5in	26%	25%	0,81 mph	10671 lb	6394 lb	50,11 psf	79,55 psf	3ft 3in	22ft 2in	5ft 10in

	Battery type	Battery charge	Add. Weight	Autonomy	Charging time	Electropump	
ECO	DC+AC 🔋🔋🔋	48V 320 A/h 5h	230V-48V 45A	990 lb	6-7 h endless	7h	48V 12 kW
ECO	DC+AC 🔋🔋	48V 270 A/h 5h	230V-48V 45A	880 lb	6-7 h endless	7h	48V 9 kW
HYBRID	Diesel+DC 🔋🔋🔋🔋🔋	24V 240 A/h 5h	230V-24V 35A	440 lb	2-3 h endless	7h	24V 5,5 kW